

Intelligent Mixer System Overview:

The traditional cable controlled hard-wired systems are certainly available, and an excellent option. For a greater level of automated safety and performance features, consider the Beck Industrial Intelligent Mixer System. This electronic control platform communicates with the truck ECM, and automates certain mixer functions to reduce distractions, improve driver safety and overall performance.

Safety Features:

- Automated drum control in transit and cannot reverse rotation and discharge in transit
- Automated hopper lower, chute lock, and disable work lights in transit
- Automatically turns on work lights in truck reverse
- Push-Button rear control disable feature from the cab box
- Mixer is in "pause" state upon engine startup
- Rear Controls are only functional when truck is in neutral and parking brake is applied
- Automated real-time status and trouble shooting diagnostics
- Safety features to come that are scalable into platform

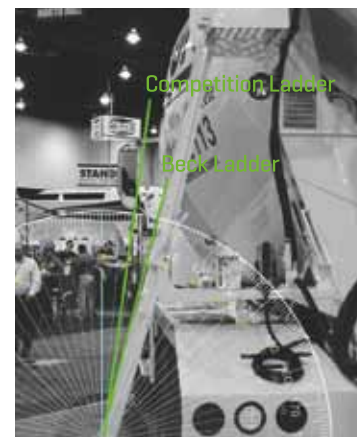

If you must have a ladder, demand the best.
Ground-Parallel Ladder Rungs

- 70% increase in boot/step contact
- Reduced stress on arms, shoulders, and legs
- Improved ascending/descending stability

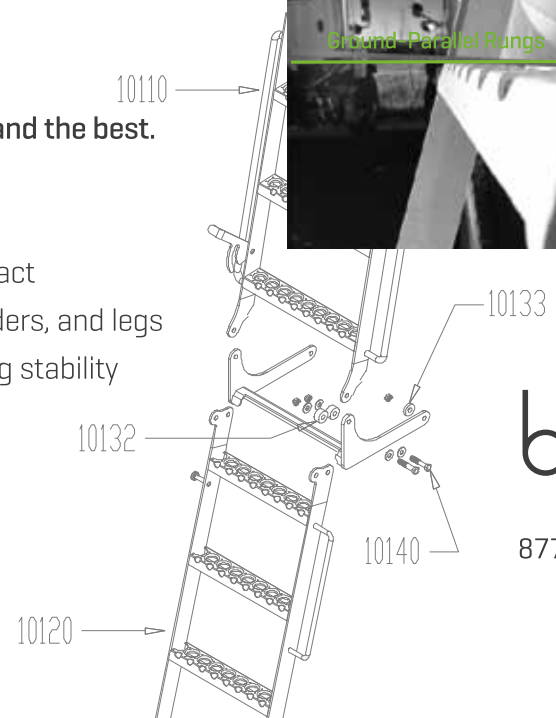

beck industrial

877-777-BECK BECKINDUSTRIAL.COM

beck
 concrete mixers

The latest safety and efficiency innovations from Beck Industrial.

SAFETY INNOVATION

The Beck Industrial SafeJet System is the first big step towards removing ladders from concrete trucks, and the latest safety and efficiency innovation from Beck Industrial.



10100 Ladder Assy w/o platform007

10110	Ladder
10120	Ladder
10125	Ladder
10132	Nylon
10133	Nylon
1C828	Bolt
1C832	Bolt
1C840	Bolt
17D6	Nut, 1/2 S
1E08	1/2 S

BECK INDUSTRIAL SAFETY INNOVATIONS

Introducing the SafeJet System

An innovative safety option that will improve job site efficiency, and may eliminate the need for a ladder. Our field-proven collection hopper and drum washout system will save time, weight, chipping, fuel, water, cleaning chemicals, and most importantly – Driver safety, recruitment, morale and retention.

Take advantage of the first system to both reduce costs and injuries, while improving profitability and driver morale. Optional today on all new Beck mixers, and retrofittable to most mixer makes and models.

- Patent pending
- Reduce or eliminate ladder use
- Cut washout time in half
- Save: weight, chipping, cleaning time, cleaning solutions, fuel, water, and man hours
- Improve driver morale, recruitment, and retention
- Available in a manual version, or fully automated with the Beck Intelligent Mixer System

Premium Safety Light Package

Powerful Grote Trilliant® LED lights positioned to cast light around the perimeter of the vehicle when work lights are active. Reduce injuries with better night visibility and reduced maintenance cost of changing incandescent low light emitting “yellow” work lights.

- Grote Trilliant® Mini Flush Mount LED White Light Lamp
- Available as replacement, upgrade bulb, complete lamp
- Built specifically for industrial / marine equipment
- 900 lumen output / lamp. 4x visibility increase
- 50,000 hour rating vs 2,000 hour incandescent rating
- Lower power consumption

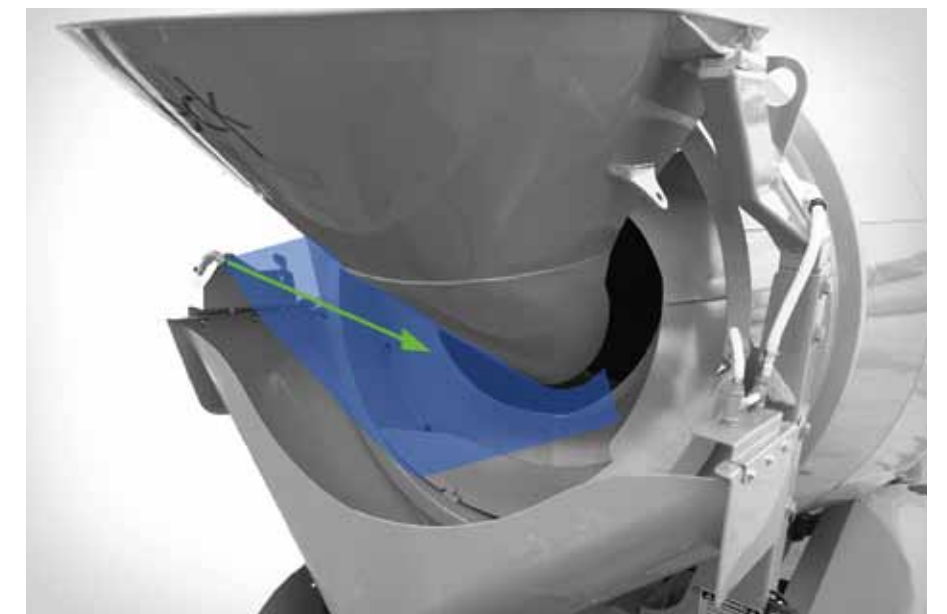
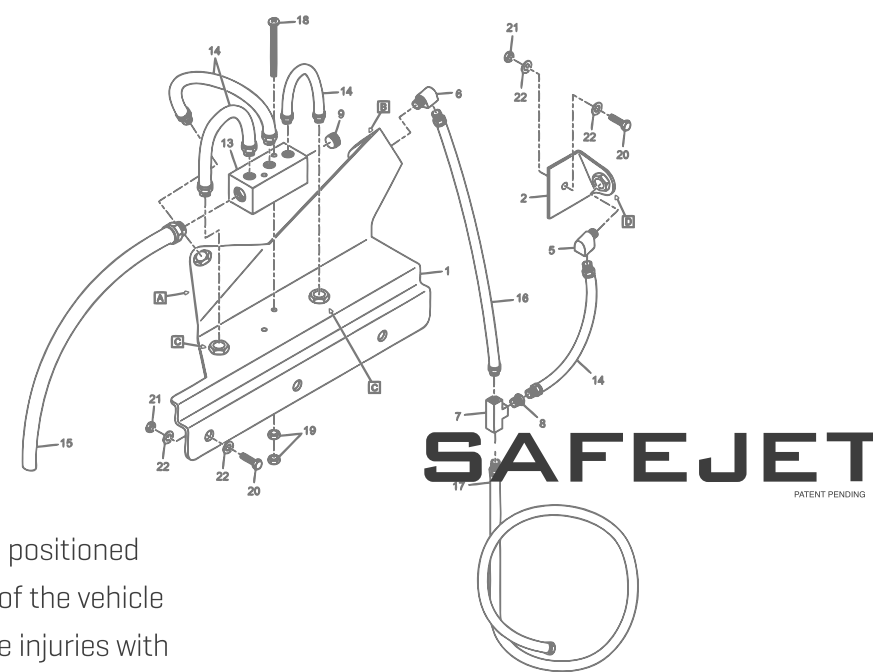
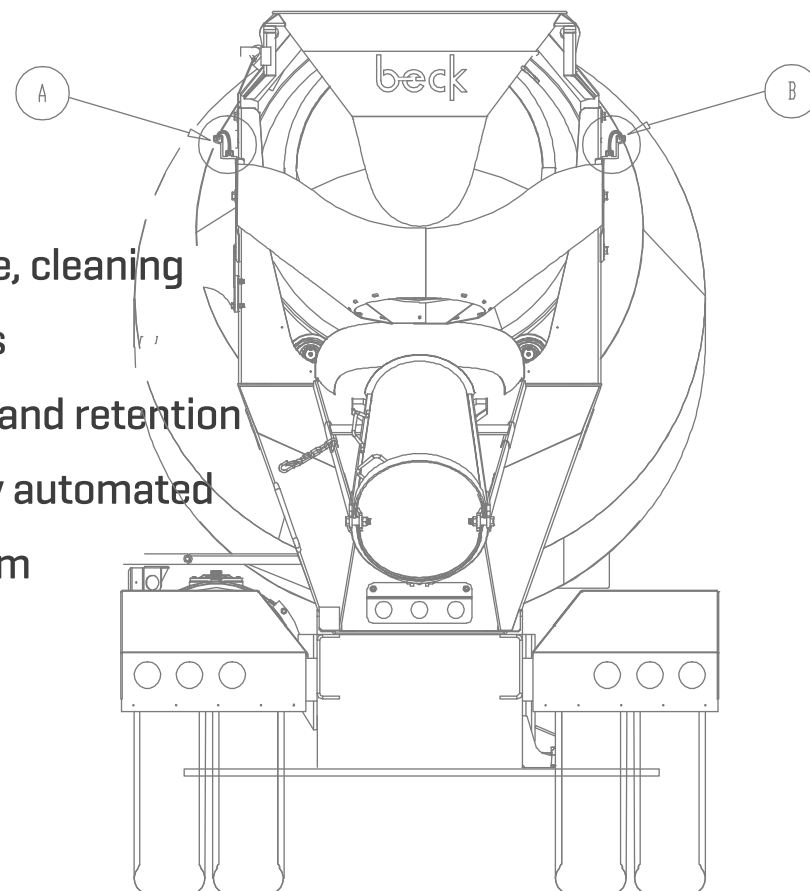

The SafeJet System is the first big step towards removing ladders from concrete trucks, and the latest safety and efficiency innovation from Beck Industrial

Powerful Grote LED lights positioned under the truck frame

